

CATCO

CATALYTIC HEATER COMPANY

HEATER ENCLOSURE PACKAGES *For Orifice Fittings*

GENERAL DESCRIPTION

The formation of ice in orifice plates may result in erratic and false gas measurements. CATCO heater enclosure packages for orifice fittings are designed to heat the orifice fitting and the plate sufficiently to prevent icing and the dropout of liquids.

Safety

Using the principle of catalytic combustion, catalytic heaters operate at a surface temperature of 600-800 F°, much lower than an open flame (approximately 1300 F°). They are a safe source of heat in areas where there are potential fire hazards from combustible gasses or liquids. They require no electrical connections except at startup, eliminating frayed wires and short circuits.

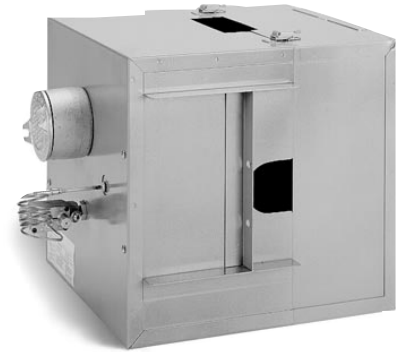

Model 70-030 with 2" or 70-038 with 4" pipe opening

DESIGN CONSIDERATIONS – ENCLOSURE DESIGNS FOR ORIFICE FITTINGS

Design of orifice fitting and orifice plate require special consideration when applying catalytic heat:

- Service of the orifice fitting does not require removal of the enclosure.
- When practical, the enclosure is made to accommodate one or two heaters as conditions require.

ADVANTAGES OF CATALYTIC HEAT

Efficiency

Catalytic heaters generate radiant (infrared) energy which can be directed on a particular object or target. Energy is not wasted on heating other objects or the air surrounding them.

Simplicity

Catalytic heaters contain no moving parts, and once energized, will function indefinitely as long as adequate supplies of air and clean fuel are provided. These factors make catalytic heaters ideal for remote applications.



Model 70-060 with open-end design for easy access

Available Models

Custom made enclosures are available for many other orifice fitting applications not depicted below.

Model 70-030 (for 2")
Model 70-038 (for 4")

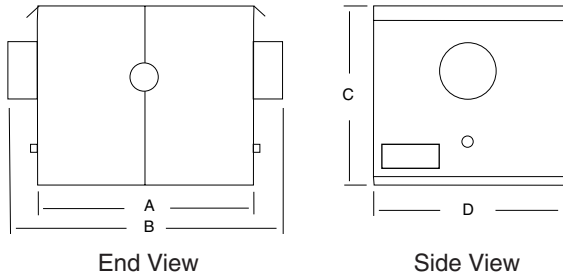

Model 70-060 (for 4")
Note: Open-end design for very easy access

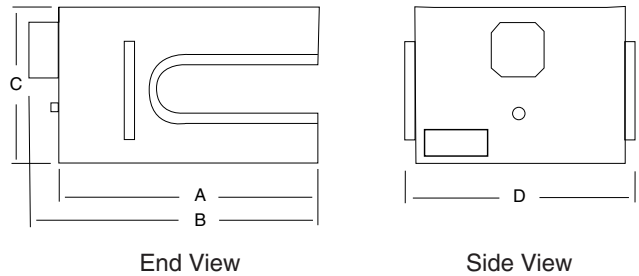

In a Hurry?

Normally, CATCO ships stock enclosure packages next day, and custom designs within a week.

CATCO enclosure packages are designed for easy installation with a minimum of tools required. In most cases installation is simply a matter of snapping the enclosure package around the appliance or pipe and supplying gas to the heater; screws and loose parts are kept to a minimum. Unless otherwise requested by the user, all parts are shipped with the enclosure package so that the unit is complete and ready to install when received in the field.

The catalytic heaters used in enclosure packages may be supplied with either 12 or 120 volt preheat systems and can be fueled with either natural gas or LPG.

FEATURES

- Sturdy (18 gauge) construction in stainless or painted steel
- Designed for quick and simple installation
- Some models accommodate the option of a second heater

OPTIONS

- Pre-wired pigtailed for convenient startups
- Explosion proof junction box
- Regulator manifold for dual heater packages
- Thermostatic controls for regulating heater output
- FM approved heaters for Class I, Div. II areas
- CGA approved heaters for Class I, Div. I & II areas

Heaters					Dimensions (inches)			
Model No.	Application	Heater Size	BTU	No. Used	A	B	C	D
70-030	2" Orifice Flange	1012	5,000 -or- 10,000	one -or- two	14.75	16.75	13.75	13.75
70-038	4" Orifice Flange	1012	5,000 -or- 10,000	one -or- two	14.75	16.75	13.75	13.75
70-060	2" Orifice Flange	1012	5,000	one	14.50	16.50	11.00	12.00